

## INTRODUCTION

The Enforcer is a unique load cell far beyond anything else available. It was designed and optimized for our users to both monitor their system or use in testing.

**Construction:** The structural components and the housing for the electronics are made from high-strength aluminum alloy machined on state-of-the-art CNC 4-axis machining centers.

**Durability:** The structural parts are very rugged. The electronics are designed with best practices in mind and are durable, but could be damaged by dropping, etc. The electronics are water resistant to light moisture, but are not waterproof and the unit should be protected from rain or other direct water exposure. If it must be used in such conditions you can wrap it in clear plastic, making sure you dry it out later. If you use it in drop or strength testing, protect it from hitting something if breakage will occur. Note: Break testing requires special care and experience.

**Operation:** Please see the separate sheet for operating the load cell.

### Instructions for Use

## ENFORCER Load Cell LC1

### EN795 & EN354 CE 0120

Structural parts manufactured in **USA** using domestic & foreign materials.

Assembled in **USA** using North American and foreign electronic subassemblies

## WARNING!

### For expert use only!

- These activities are inherently dangerous and carry a significant risk of injury or death that cannot be eliminated.
- It is the user's responsibility to obtain specific training and to use it safely. These instructions DO NOT tell you everything you need to know.
- Do not use unless you can and will understand and assume all risks and responsibilities for all damage/injury/death that may result from use of this equipment or the activities undertaken with it.
- Any device is subject to failure-carefully check before and after each use.
- You must always have a backup-never trust a life to a single tool.
- Everyone using this equipment must be given and thoroughly understand the instructions and refer to them before each use.
- You must have a rescue plan and the means to implement it. Inert suspension in a harness can quickly result in death!
- Do not use around electrical hazards, moving machinery or near sharp edges or abrasive surfaces.
- We are not responsible for any direct, indirect or accidental consequences or damage resulting from the use of our products.

**rockexotica.com**

rock exotica equipment LC  
POB 160470  
Freeport Center, F-11  
Clearfield, UT 84016  
USA  
801 728-0630

LC1500 9/2013 A

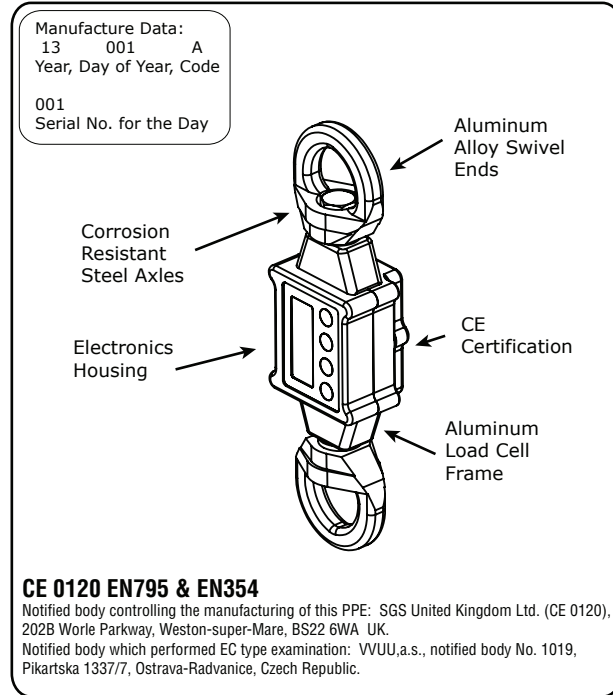

### TESTING CAPACITY

The Enforcer will measure up to 20kN. If you exceed 20kN it will permanently say "Overloaded" on the display. You can still use it for testing, but not for life safety.

You should establish your own Working Load Limit depending on use. For example a 6:1 safety factor from the 36kN breaking strength would be a WLL of 6kN.

**Back It Up!** Our customers work in dangerous situations where many things can go wrong. You should always be able to back up the Enforcer and reduce the risk of an accident.

**Calibration:** You should occasionally apply a known force to verify the Enforcer is accurate. Be aware in use and stop and check if forces don't seem reasonable. Depending on usage, we recommend you send your Enforcer to us annually for calibration. Turn around time is approximately 3 days. Please contact us for current cost.

	LC1
<b>Strength</b>	36kN
<b>Max Measurement</b>	20kN
<b>Length</b>	8.0" (203mm)
<b>Width</b>	2.1" (53mm)
<b>Thickness</b>	1.5" (38mm)
<b>Weigh</b>	14 oz. (397gm)

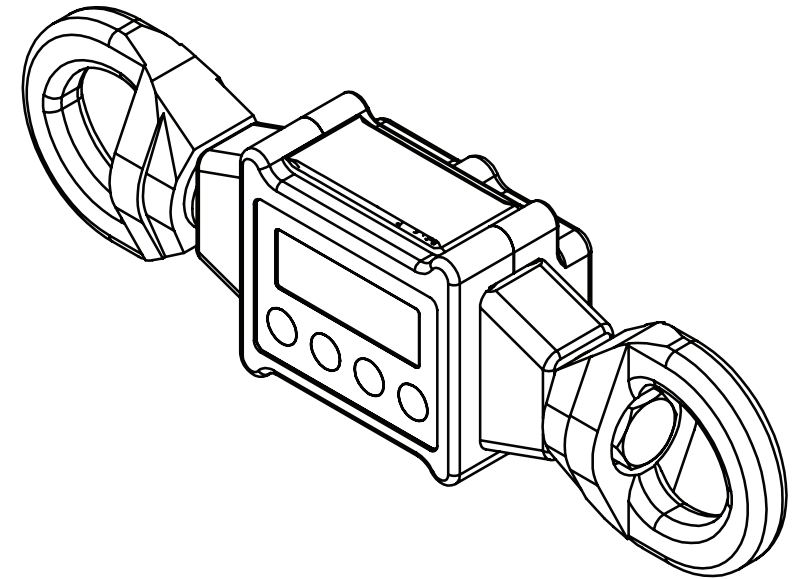

See Separate Instruction Card For Operating the Load Cell

### Intended Use

Only the loading shown as "OK" is allowed. Always verify proper positioning of your system and components. The Enforcer must be free to align with the load, any restraint is dangerous. Make sure you use redundant systems. Stack must be kept out of the system. If the swivel is not observable or is not under constant tension, use closed rings (screw links, etc.) or loops (webbing, etc.) that cannot be broken. This product is intended for use by medically fit, specifically trained and experienced users.

### Anchors

Must meet the EN 795 standard. Strength must meet the needs of the particular situation (at least 10kN) and the user must always stay below the anchor. Clearance under the user must always be enough to prevent hitting anything in case of a fall (the length of this equipment can influence the height of a fall).

### Leverage Hazard

A swivel or other equipment can lever against a connector (such as a carabiner) and break it, opening the connector and allowing the pulley to fall out. Guard against this at all times! The Swivel must always be under tension in your system to avoid shifting into an incorrect position.

### Stay Up To Date!

Regularly go to our website and read the latest user instructions.

Copyright 2013 Rock Exotica LLC

### Inspect Before & After Use

Check all parts for cracks, deformation, corrosion, wear, etc. Verify that the swivel ends rotate normally & the axle screws have not loosened.

### Inspection During Use

Regularly inspect and monitor your system, confirming proper connections, equipment position, fully locked connectors, etc.

### Thorough and specific training is absolutely essential before use.

Being at height is dangerous and it is up to you to reduce the risks as much as possible - but the risks can never be eliminated. There are many ways to misuse this equipment, too many to list or imagine. You must personally understand and assume all risks and responsibilities of using this equipment. If you cannot or do not want to do this, do not use this equipment.

### Environmental Factors

Moisture, ice, salt, sand, snow, chemicals and other factors can prevent proper operation or can greatly accelerate wear and may damage the electronics

### Compatibility

Verify compatibility with other components of your system. Incompatible connections can cause detachment, breakage, etc. If a swivel is used with cable it must be anti-rotation cable!

### Lifetime

Lifetime is indefinite and depends on usage and conditions. Lifetime can be short or it could even be a single use in some cases.

### Retire from Service & Destroy if it:

1. Is significantly loaded.
2. Does not pass inspection or there is any doubt about its safety.
3. Is misused, altered, damaged, exposed to harmful chemicals, etc.
4. Does not rotate smoothly. Consult the manufacturer if you have any doubts or concerns.

### Maintenance & Storage

Clean if necessary with damp cloth, then allow to dry completely. Do not get water on electronics. Store in a dry place away from extremes of heat and cold and avoid chemical exposure.

### Principal Material

Aluminum alloy, anodized. Corrosion resistant steel axle.

### Repairs or Modifications to Equipment

Are only allowed by the manufacturer or those

### Detailed Inspection

In addition to inspection before, during and after each use, a detailed inspection by a competent inspector must be done at least every 12 months or more frequently depending on amount and type of use. Make a copy of these instructions and use one as the permanent inspection record and keep the other with the equipment. It is best to issue new gear to each user so they know its entire history.

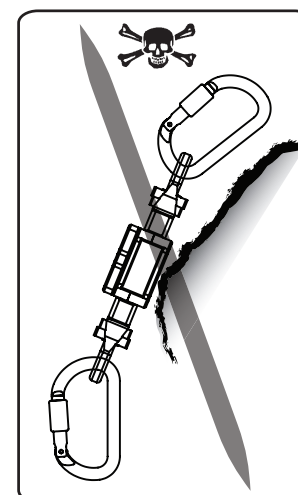
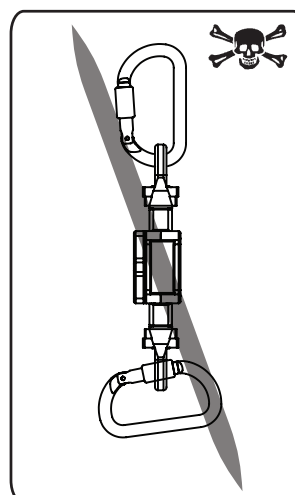
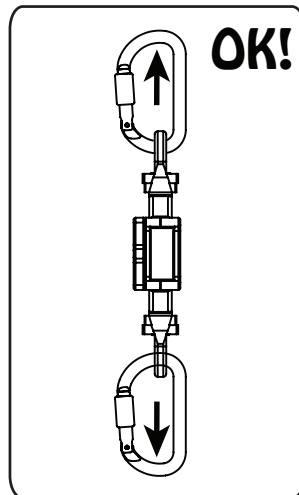

PURCHASE RECORD	
Model	
Complete Batch #	
Year of Manufacture	
Purchase Date	
Date of 1st Use	
User	

DATE	CONDITION	INSPECTOR

### TEMPERATURE DISPLAY

In *slow* mode:  
Temperature measurement in °C or °F depending on the UNITS.





In *fast* mode:  
bl 2: indicating the „block“ that the data is being logged to. There are 4 blocks, bl1, bl2, bl3 and bl4.

 is displayed when the force has exceeded the trigger value (4 kN default) and the device is sampling data. Only in *fast* mode.

**LOADED** is displayed when the device is in *fast* mode and loaded above the trigger value. To re-trigger, unload or switch to *slow* momentarily. This is to avoid continuous re-triggering.

**OVERLOADED** is displayed when force exceeds the maximum value of 20.0 kN and indicates the device is no longer safe to use in life critical applications. The device continues to function normally.

### BATTERY INDICATION

-  Full battery
-  40-80% remaining
-  10-40% remaining
-  Battery empty, logging disabled

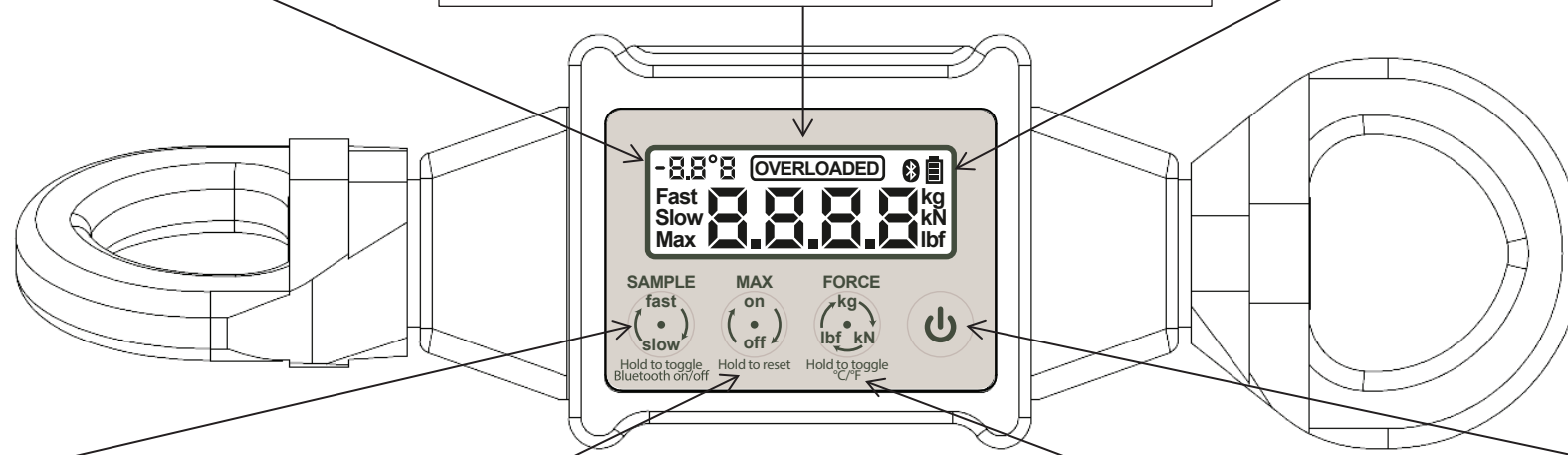

### SAMPLE

Press to toggle between:

- **slow** 2 sample/second.  
Best battery performance.
- **fast** 500 samples/second.  
Use to capture dynamic events. Trigger enabled.  
No temperature compensation in *fast* mode.

Hold to turn Bluetooth on/off  
- Bluetooth sign in upper right corner indicates that Bluetooth is on

### MAX

Press to display maximum value:

- **on** Maximum value displayed.  
Max indicated in lower left.
- **off** currently measured value displayed.

Hold to reset the maximum value.

### FORCE

Press to change between:

- **kN** ±0.1 kN, max 20.0 kN
- **kg** ±10 kg, max 2040 kg
- **lbf** ±20 lbf, max 4500 lbf

Hold to switch between:  
- °C  
- °F

### POWER

Hold for 2s to turn on and off

**RESET ZERO:** Press POWER and simultaneously UNITS

# ENFORCER

Quick Reference Card